

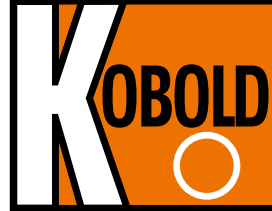

Brass Ball Valves

2- and 3-way ball valves with screw thread



measuring
•
monitoring
•
analysing

KUG-TB, -AG, -IK,
-VN, -VL

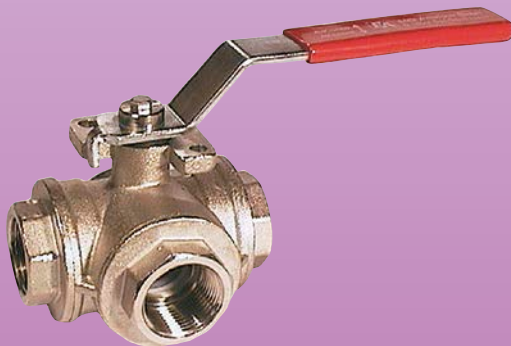
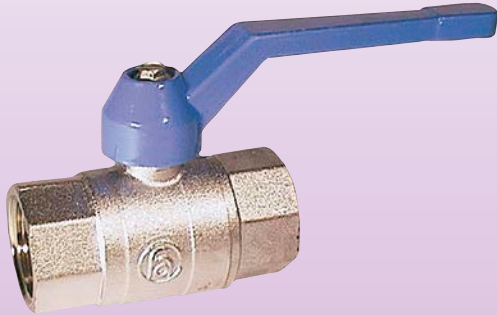

- p_{max} : PN40; t_{max} : 160°C
- Connections: G ¼ ... G 3 screw thread
- For steam, gaseous, liquid and viscous media
- With handle
- Also with DIN-DVGW approval
- T and L bore (3-way version)
- Reasonably priced



Z1

KOBOLD companies worldwide:

AUSTRALIA, AUSTRIA, BELGIUM, BULGARIA, CANADA, CHINA, CZECHIA, FRANCE, GERMANY, GREAT BRITAIN, HUNGARY, INDIA, INDONESIA, ITALY, MALAYSIA, MEXICO, NETHERLANDS, PERU, POLAND, REPUBLIC OF KOREA, RUSSIA, SPAIN, SWITZERLAND, THAILAND, TUNISIA, TURKEY, USA, VIETNAM

KOBOLD Messring GmbH
Nordring 22-24
D-65719 Hofheim/Ts.
☎ Head Office:
+49(0)6192 299-0
+49(0)6192 23398
✉ info.de@kobold.com
www.kobold.com

Design

Two-piece threaded joint body design with full cylindrical bore.

Materials

Body: brass, nickel-plated
 Ball: brass, hard-chrome plated
 Ball gasket: PTFE
 Spindle gasket: FKM
 Handle: aluminium alloy, epoxy resin coated
 blue or red

Technical Details

Connections: female/female thread G ¼ ... G 3
 female/male thread G ¼ ... G 2
 Temperature range: -20 °C ... +120 °C
 Nominal pressure: PN25 ... 80
 Operation: handle has rotating range of 90° (can be offset by 180° against the spindle)

KUG-TBR

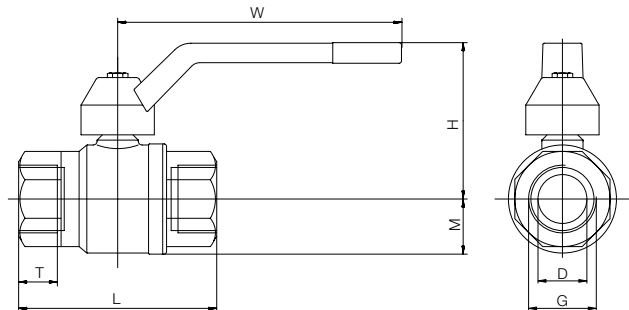

KUG-TBB

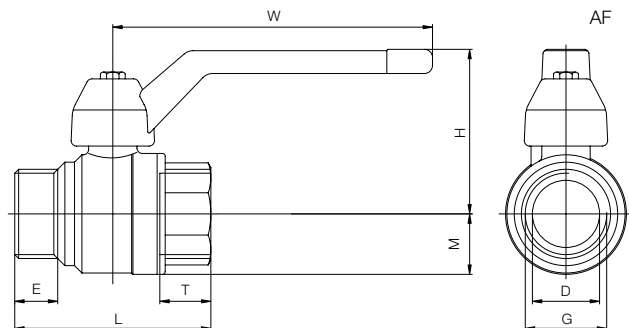

Dimensions and Order Details (example: KUG-TBR 08)

Screw thread [G]	Order no. female thread	Order no. female/male thread	D [mm]	L [mm]	T [mm]	E [mm]	H [mm]	M [mm]	W [mm]	Weight [kg]
¼	KUG-TBR 08	KUG-TBB 08	8	45	11	9	33	10.5	75	0.1
⅜	KUG-TBR 10	KUG-TBB 10	10	45	11	10	33	11.5	75	0.1
½	KUG-TBR 15	KUG-TBB 15	15	56	14	12	49	15.5	90	0.2
¾	KUG-TBR 20	KUG-TBB 20	20	65	15	13	50	19.0	90	0.3
1	KUG-TBR 25	KUG-TBB 25	25	74	17	15	65	22.5	120	0.5
1¼	KUG-TBR 32	KUG-TBB 32	32	85	18	16	70	28.0	120	0.7
1½	KUG-TBR 40	KUG-TBB 40	40	98	20	17	80	35.0	150	1.1
2	KUG-TBR 50	KUG-TBB 50	49	110	21	20	87	42.0	150	1.5
2½	KUG-TBR 65	-	64	134	21	-	120	55.0	200	2.9
3	KUG-TBR 80	-	78	160	25	-	135	65.0	240	4.8



Design

Two-piece threaded joint body design with full cylindrical bore. Stamped from Rp 1/2 acc. AD-approval A 4.

Materials

Body: brass, nickel-plated
 Ball: brass, hard-chrome plated
 Ball gasket: PTFE
 Spindle gasket: FKM
 Handle: aluminium alloy, epoxy resin coated blue

Technical Details

Connections: female thread Rp 1/4 ... Rp 2 (acc. to DIN 2999)
 Temperature range: -20 °C ... +120 °C
 Nominal pressure: see tabelle to 80 °C
 Operation: handle has rotating range of 90° (can be offset by 180° against the spindle)

KUG-AG

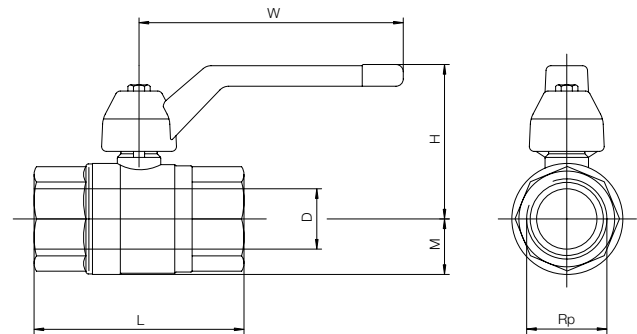

Dimensions and Order Details (example: KUG-AGR 08)

Screw thread [Rp]	Order no. female thread	D [mm]	L [mm]	H [mm]	M [mm]	W [mm]	Weight [kg]	P _{max} [bar]
1/4	KUG-AGR 08	6	50	32	10.0	75	0.11	40
3/8	KUG-AGR 10	10	55	42	12.5	75	0.12	40
1/2	KUG-AGR 15	15	65	50	16.0	90	0.24	40
3/4	KUG-AGR 20	20	75	53	19.0	90	0.35	40
1	KUG-AGR 25	24	86	62	23.0	120	0.64	40
1 1/4	KUG-AGR 32	30	95	70	28.0	120	1.0	32
1 1/2	KUG-AGR 40	38	101	78	35.0	150	1.11	30
2	KUG-AGR 50	47	120	85	42.0	150	1.97	30

Minimum order quantity: 20 pcs., mixed sizes possible

DIN DVGW Registration Number NG-4312BN0021

Design

Two-piece threaded joint body design with full cylindrical bore. For all gases as per DVGW worksheet G 260/I for gas stop valves.

Materials

Body: brass, nickel-plated
 Ball: brass, hard-chrome plated
 Ball gasket: PTFE
 Spindle gasket: NBR/FPM
 Handle: galvanised steel, epoxy resin coated yellow

Technical Details

Connections: female thread Rp ¼ ... Rp 2 (acc. to ISO 7/1)
 Temperature range:
 Gas: -15 °C ... +60 °C
 Air: -20 °C ... +220 °C
 Water: 0 °C ... +150 °C
 Nominal pressure: PN 1 ... 4 for gas
 PN 25 ... PN 50 (for other media without DVGW approval)
 Operation: handle has rotating range of 90°

KUG-IK

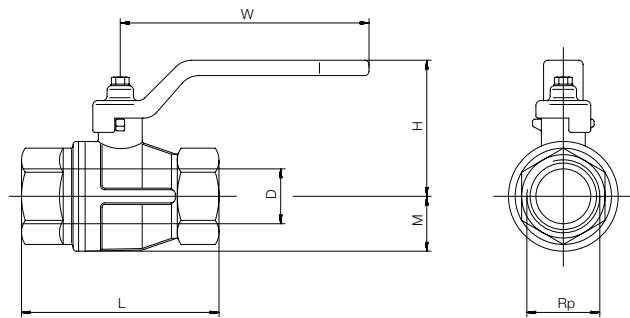

Dimensions and Order Details (example: KUG-IKR 08)

Screw thread [Rp]	Order no. female thread	D [mm]	L [mm]	H [mm]	M [mm]	W [mm]	Nominal pressure water [PN]	Weight [kg]
¼	KUG-IKR 08	10	50	37	12	80	50	0.15
⅜	KUG-IKR 10	10	53	37	12	80	50	0.27
½	KUG-IKR 15	15	61	49	16	89	50	0.27
¾	KUG-IKR 20	20	68	55	19	113	40	0.41
1	KUG-IKR 25	25	85	59	23	113	40	0.57
1¼	KUG-IKR 32	32	100	75	29	138	30	0.90
1½	KUG-IKR 40	40	109	90	36	158	30	1.28
2	KUG-IKR 50	50	130	97	43	158	25	1.92

Minimum order quantity: 20 pcs., mixed sizes possible

Design

Four-piece threaded joint body design with mounting pad for actuator mounting, full cylindrical bore, T or L bore, sealing on all ports. Does not prevent crossover flow.

Materials

Body: brass, nickel-plated
 Ball: brass, hard-chrome plated
 Ball gasket: PTFE
 Spindle gasket: PTFE and FKM
 Handle: zinc-coated steel, plastic sheathed, red

Technical Details

Connections: G 1/4 ... G 2
 Temperature range: -20 °C ... +150 °C
 Nominal pressure: PN 10 ... PN 30 ... 80 °C (see table)
 Operation: handle has rotating range of 90° (can be offset by 90° against the spindle)

Positions

	T-bore				L-bore		
Handle or actuator mounting							
0° position							
90° position							

KUG-VN

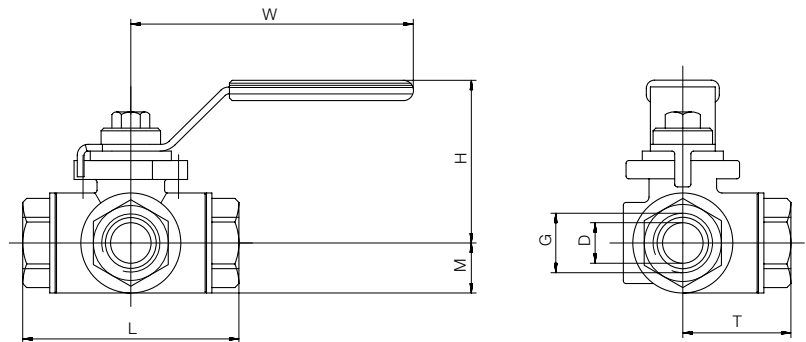
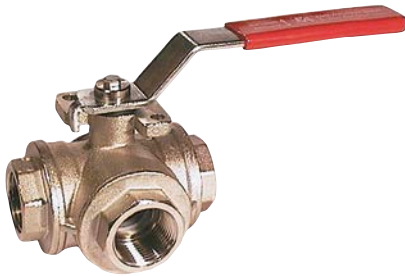

Dimensions and Order Details (example: KUG-VNTR 08)

Screw thread [G]	Order no. T-bore	Order no. L-bore	Nom. size D [mm]	L [mm]	H [mm]	M [mm]	W [mm]	T [mm]	Nominal pressure [PN]	Value k_v [m³/h]	Weight [kg]
1/4	KUG-VNTR 08	KUG-VNLR 08	8	67.0	62.5	17.0	120	33.5	30	2.8	0.55
3/8	KUG-VNTR 10	KUG-VNLR 10	10	67.0	62	17.0	120	33.5	30	3.0	0.52
1/2	KUG-VNTR 15	KUG-VNLR 15	15	77.0	63.5	20.0	120	38.5	30	3.9	0.65
3/4	KUG-VNTR 20	KUG-VNLR 20	20	87.0	75	24.0	170	43.5	30	7.9	1.10
1	KUG-VNTR 25	KUG-VNLR 25	25	105.0	79.5	30.0	170	52.5	16	13.0	1.83
1 1/4	KUG-VNTR 32	KUG-VNLR 32	32	122.5	93	36.0	170	61.5	10	20.7	2.75
1 1/2	KUG-VNTR 40	KUG-VNLR 40	40	138.5	113.5	43.0	230	69.5	10	38.7	4.57
2	KUG-VNTR 50	KUG-VNLR 50	50	166.0	123.5	55.5	230	83.0	10	54.0	8.37



3-way Brass Ball Valve for Manual Operation, Full Bore Model KUG-VL

Design

Design: two-piece threaded joint body design with full bore, T or L bore, sealed on two ports.

Materials

Body: brass, nickel-plated
 Ball: brass, hard-chrome plated
 Ball gasket: PTFE
 Spindle gasket: PTFE/NBR
 Handle: zinc-coated steel, plastic sheathed, black (G 2 and G 3 aluminium alloy)

Technical Details

Connections: G 1/4 ... G 3
 Temperature range: -15 °C ... +120 °C
 Nominal pressure: PN 6 ... 25 (see table)
 Operation: handle has rotating range of 180° (can be offset by 180° against the spindle)

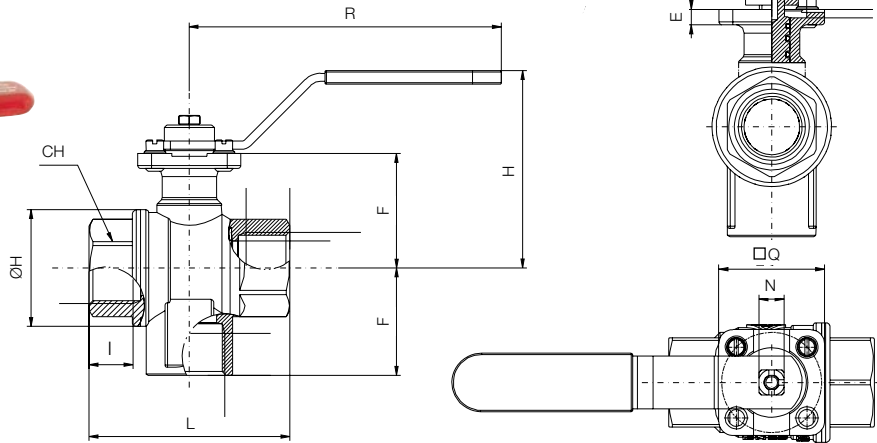
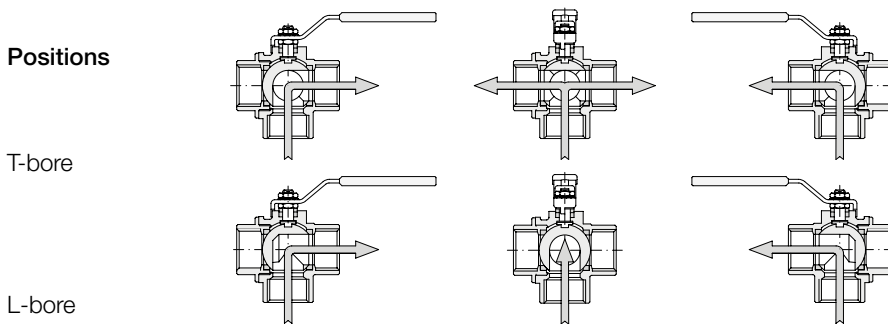

Dimensions and Order Details (example: KUG-VLTR 08)

Screw thread [G]	Order no. T-bore	Order no. L-bore	DN	I	CH	ØD	E [mm]	F [mm]	N [mm]	Q [mm]	ØH [mm]	L [mm]	H [mm]	R [mm]	Kv [m³/h]	PN	Weight »L« [kg]	Weight »T« [kg]
1/4	KUG-VLTR 08	KUG-VLLR 08	8	11	22	25	5,5	28,5	9	38	28	52	60	115	1,5	25	0,22	0,22
3/8	KUG-VLTR 10	KUG-VLLR 10	10	11,4	22	25	5,5	28,5	9	38	28	52	60	115	1,8	25	0,19	0,19
1/2	KUG-VLTR 15	KUG-VLLR 15	15	15	27	25	5,5	31	9	38	34,5	64	62	115	3,9	25	0,30	0,30
3/4	KUG-VLTR 20	KUG-VLLR 20	20	16,3	32	25	5,5	42	9	38	43	74	43	115	7,9	16	0,49	0,47
1	KUG-VLTR 25	KUG-VLLR 25	25	19,1	41	25	6	45	9	38	53	89	76	115	13	16	0,78	0,76
1 1/4	KUG-VLTR 32	KUG-VLLR 32	32	21,4	50	25	6	49	9	38	63	100	79,5	115	20,7	10	1,16	1,18
1 1/2	KUG-VLTR 40	KUG-VLLR 40	40	21,4	55	35	8	61,5	11	50	77	110	95	170	38,7	10	1,71	1,53
2	KUG-VLTR 50	KUG-VLLR 50	50	25,7	70	35	8	67	11	50	93	130	101	170	54	10	2,85	2,60
3	KUG-VLTR 80	-	80	33,3	105	no mounting pad acc. to ISO 5211			20		148	197	152	260	145	6	9,50	9,20