

**Operating Instructions**  
**for**  
**Compact Vortex Flow Meter**

**Model: Y-DVZ45001/PS25**

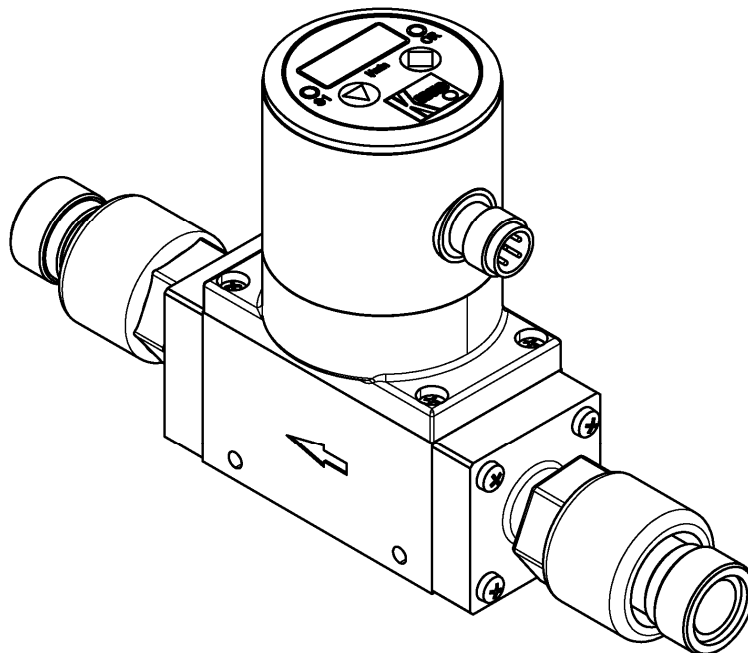

## 1. Contents

---

1. Contents.....	2
2. Note .....	3
3. Instrument Inspection.....	3
4. Regulation Use .....	4
5. Operating Principle.....	4
6. Mechanical Connection.....	5
6.1 Check operating conditions.....	5
6.2 Installation.....	5
6.3 Serto installation instructions .....	6
7. Electrical Connection .....	8
8. Adjustments – Compact Electronic .....	9
8.1 Button function .....	9
8.2 Settings.....	10
8.3 Value setting .....	10
8.4 Set-up mode .....	11
8.5 Main menu items .....	12
9. Maintenance .....	14
10. Technical Information.....	15
11. Order Codes .....	15
12. Dimensions .....	15
13. Disposal .....	16
14. EU Declaration of Conformance .....	17
15. UK Declaration of Conformity.....	18

### Manufactured and sold by:

Kobold Messring GmbH  
Nordring 22-24  
D-65719 Hofheim  
Tel.: +49(0)6192-2990  
Fax: +49(0)6192-23398  
E-Mail: [info.de@kobold.com](mailto:info.de@kobold.com)  
Internet: [www.kobold.com](http://www.kobold.com)

---

## 2. Note

---

Please read these operating instructions before unpacking and putting the unit into operation. Follow the instructions precisely as described herein.

The instruction manuals on our website [www.kobold.com](http://www.kobold.com) are always for currently manufactured version of our products. Due to technical changes, the instruction manuals available online may not always correspond to the product version you have purchased. If you need an instruction manual that corresponds to the purchased product version, you can request it from us free of charge by email ([info.de@kobold.com](mailto:info.de@kobold.com)) in PDF format, specifying the relevant invoice number and serial number. If you wish, the operating instructions can also be sent to you by post in paper form against an applicable postage fee.

Operating instructions, data sheet, approvals and further information via the QR code on the device or via [www.kobold.com](http://www.kobold.com)

The devices are only to be used, maintained and serviced by persons familiar with these operating instructions and in accordance with local regulations applying to Health & Safety and prevention of accidents.

When used in machines, the measuring unit should be used only when the machines fulfil the EC-machine guidelines.

### **as per PED 2014/68/EU**

In acc. with Article 4 Paragraph (3), "Sound Engineering Practice", of the PED 2014/68/EU no CE mark.

Diagram 8, Pipelines, Group 1, dangerous fluids

---

## 3. Instrument Inspection

---

Instruments are inspected before shipping and sent out in perfect condition.

Should damage to a device be visible, we recommend a thorough inspection of the delivery packaging. In case of damage, please inform your parcel service / forwarding agent immediately, since they are responsible for damages during transit.

### **Scope of delivery:**

The standard delivery includes:

- Compact Vortex Flow Meter      model: Y-DVZ45001/PS25

## 4. Regulation Use

---

Any use of the Compact Vortex Flowmeter, model: Y-DVZ45001/PS25, which exceeds the manufacturer's specifications, may invalidate its warranty. Therefore, any resulting damage is not the responsibility of the manufacturer. The user assumes all risk for such usage.

## 5. Operating Principle

---

The compact KOBOLD Vortex flow meter Type Y-DVZ45001/PS25 is used for measuring and monitoring smaller and medium-sized flow of low viscosity, water-like fluids in pipes. The device works using the vortex process, making it virtually maintenance-free. This involves the installation of a sharp-edged object (the vortex generator) in the flow duct. A vortex is created behind the object whose frequency is proportional to the velocity of flow of the fluid. The flow volume can be determined with a very great degree of accuracy by measuring the vortex frequency. This achieves a very high linearity across the whole measuring range. The device can be fitted with switching, frequency or analogue outputs. There is also an optional compact electronics package that includes a digital display, and both a switching and analogue output.

---

## 6. Mechanical Connection

---

### 6.1 Check operating conditions

- Flow rate
- max. operating pressure
- max. operating temperature

### 6.2 Installation

- Remove all packing materials and transport retainers and ensure that no such materials remain in the device.
- Install with flow in direction of arrow (universal mounting)
- Avoid pressure and radial tension
- Fasten the pipe at up stream and down stream at a distance of 50 mm from the connections
- Install the compression fitting (see section 6.3)
- Ensure inlet and outlet section of 10xDN (e.g. 10x nominal pipe diameter)
- Avoid valves or large reduction on the inlet section (this increases the inaccuracy of measurements)
- Check the seals of the connections



---

**Caution! When used with an open output side, there is a danger of cavitation.**

---

## 6.3 Serto installation instructions

### 1. Preparation

Cut the tube to length and deburr it. The tube must be straight and free from blemishes for approximately 1,5 d from the end. The union is lubricated. Thus lubrication with lubricating oil, MoS<sub>2</sub>, Teflon etc. is recommended for the assembly and reassembly of bigger sized unions (thread, compression ferrule).

### 2. Reinforcing the tube and pushing it in

Stiffener sleeves\* are required to reinforce plastic tubes and thin walled tubes

<b>Copper</b>	from d 10 mm with s < 1,0 mm from d 12 mm with s < 1.5 mm
<b>Stainless steel</b>	from d 6 mm with s < 0.5 mm from d 10 mm with s < 1.5 mm
<b>Plastic</b>	all

Align tube and union. Insert the tube as far as the stop. Details see chapter tubes in the appendix. [www.serto.com](http://www.serto.com)

### 3. Compression, stress relieving

3.1 Screw on the union nut by hand until finger tight.

At the same time, push the tube against the fitting.

3.2 Tighten down the union nut 1% rotation using an open ended spanner. (Making a mark will assist in correct rotation.)

3.3 Slightly release the nut once again to take the radial stress off the tube.

3.4 Checking of fit. A distinct bead or deformation must be visible on the inside of the tube.

3.5 Screw on the union nut until finger tight again and tighten down the union nut with + rotation for the final fit. (Hold adaptor from turning with a second wrench.)

### 4. Repeated fitting of the union

When refitting the same tube union, screw the union nut back on by hand until finger tight and tighten down the union nut with an open ended spanner + rotation for the final fit.

**In case of repeated assembly, parts must be lubricated.**

Tubes\*

Tubes with a clean smooth external surface and with an outside diameter within the tolerance  $\pm 0.1$  mm should be used.

Turnable compression ferrule

It is of no detriment to the efficiency of the connection if, after assembly, the ferrule can be turned on the tube, or the tube in the union nut.

Pre-assembly stud

SO 56000, stainless steel, tuffride treatment, for stainless steel and brass M-Programme. SO 6000, CrNi steel hardened, for steel.

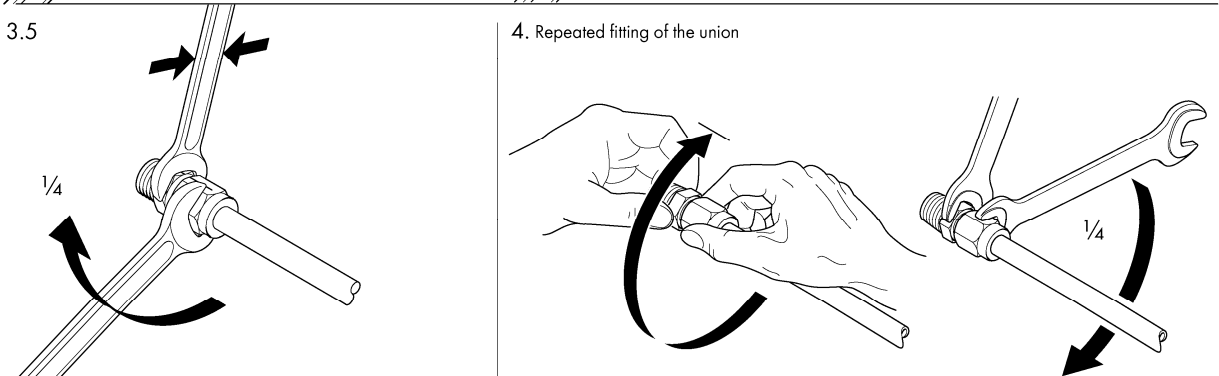
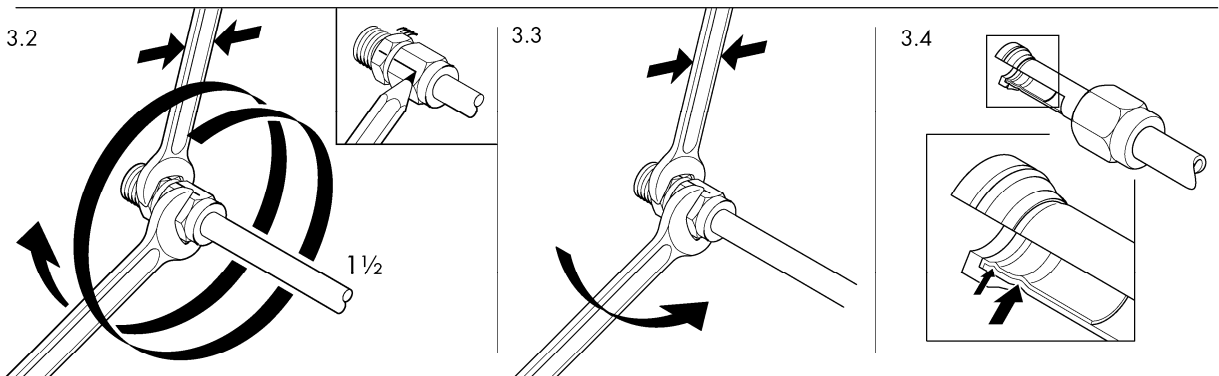
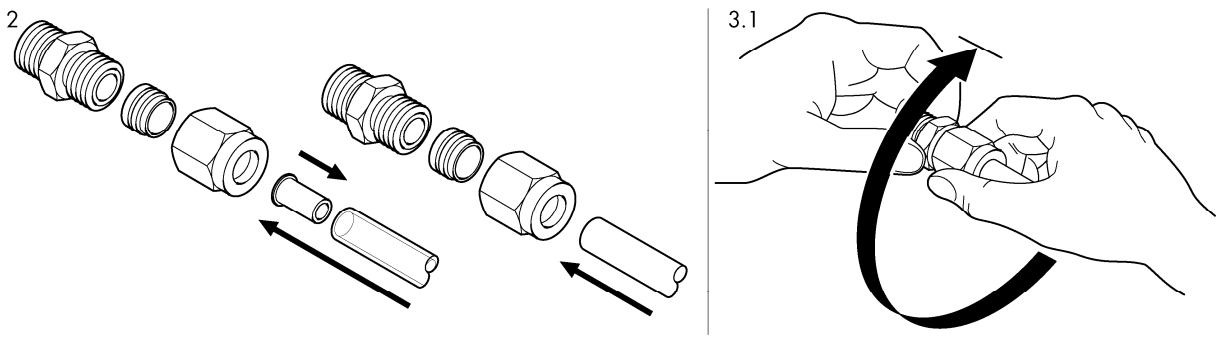
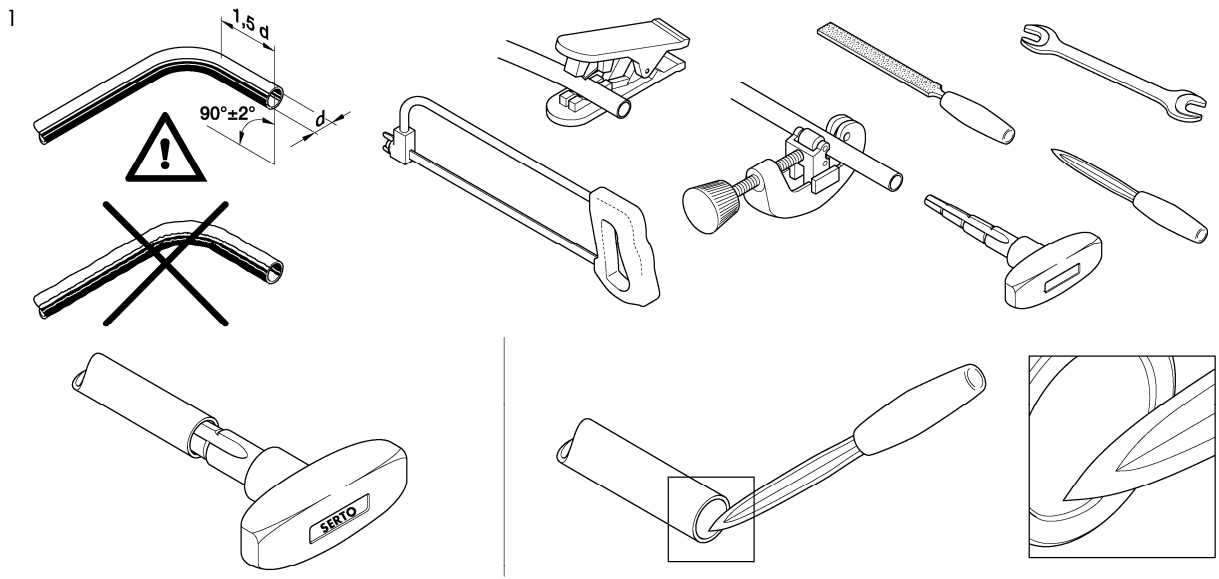

## 7. Electrical Connection

---



**Caution! Make sure that the voltage values of your system correspond with the voltage values of the measuring unit.**

- Make sure that the supply wires are de-energized.
- Plug in the system according to the connecting diagrams.
- We recommend the use of wires with cross sectional area of min. 0.25 mm<sup>2</sup>

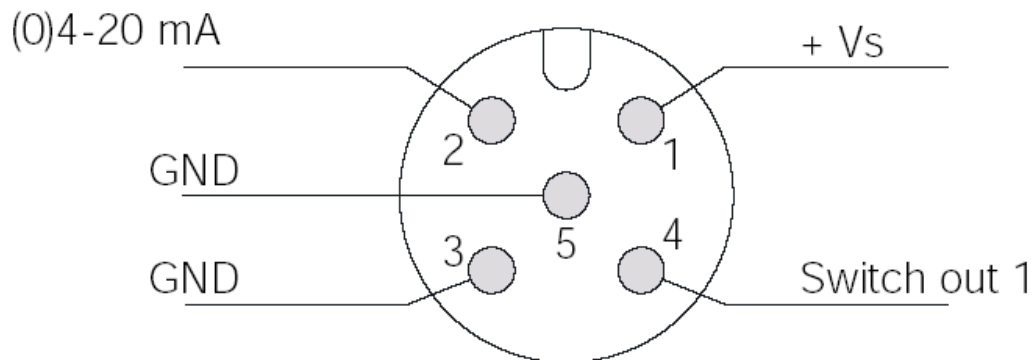





## 8. Adjustments – Compact Electronic



Connect the compact electronic according to previous connection diagram. After power on, the measuring range (end current) will be shown for 3 seconds.

### 8.1 Button function

In the normal mode (measuring mode)

 : Press 3 sec. → Setup mode  
 : Switch point/ Window point

In the set-up mode

 : Next Step  
 : Change Value

Any time

3 sec 

or do not press  
a button for 20 sec

↓

Standard mode

## 8.2 Settings

The following values can be changed at the temperature transmitter:

	Scale range	Factory setting
Switch point ( <b>SPo</b> )	0...999	0.00
Hysteresis ( <b>HYS</b> )	-199...0	-0.00
Window point (duo point) ( <b>duo</b> )	Switch point ...999	--- (inactive)
contact-type ( <b>Con</b> )	N/O, N/C or Frequency ( <b>Fr</b> )	<b>N/O</b>
Start current ( <b>S-C</b> )*	000...999	000
End current ( <b>E-C</b> )*	000...999	FS
Start current selection ( <b>SCS</b> )	0-- (0 mA), 4-- (4 mA)	4 mA
Change Code ( <b>CCo</b> )	000...999	000**

\* Start- and End value of flow relating to 0/4-20 mA.

\*\* If you do not remember your code-number, you have to send the unit back to Kobold.

## 8.3 Value setting

From the main menu item (for example: switch point, "**SPo**"), press the "◆" button to set the value. The flow chart below illustrates the universal routine for changing individual parameters.

[From the main menu item]

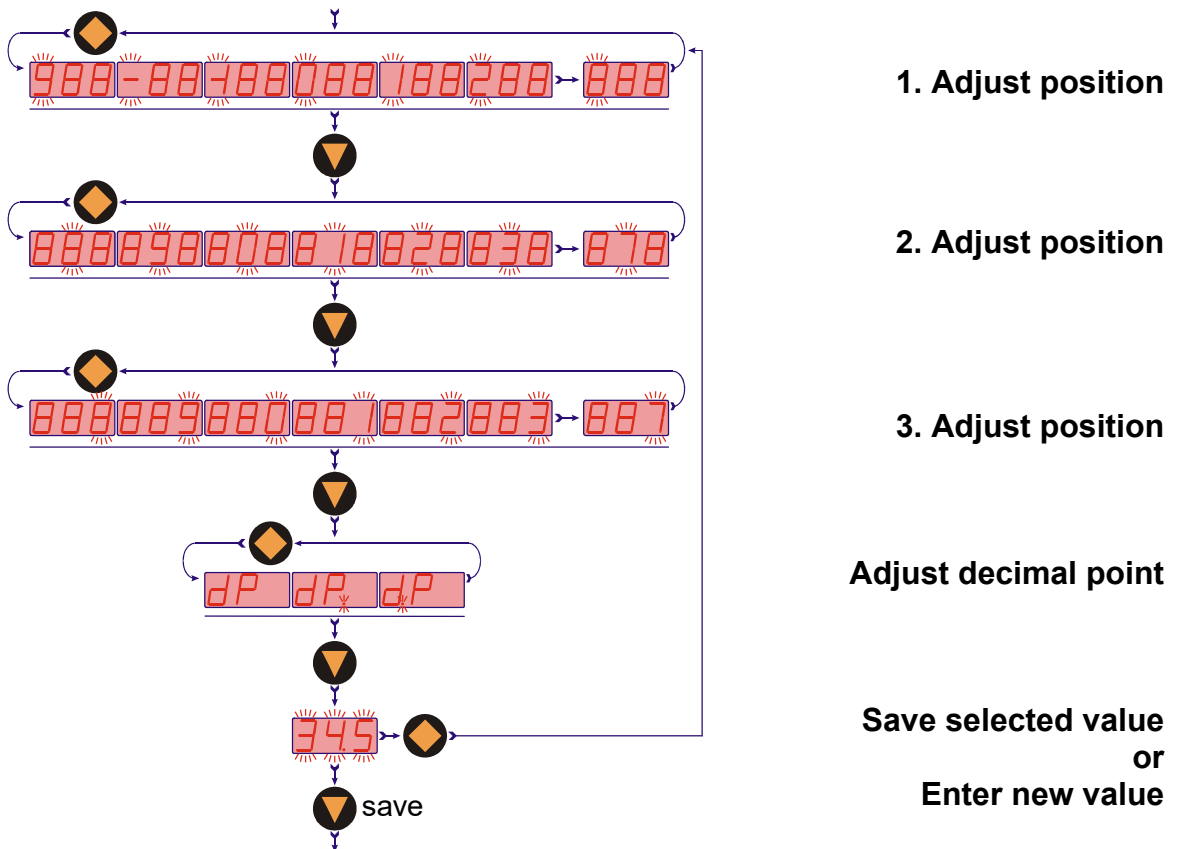

item]

[To the next main menu

## 8.4 Set-up mode

### Compact electronic

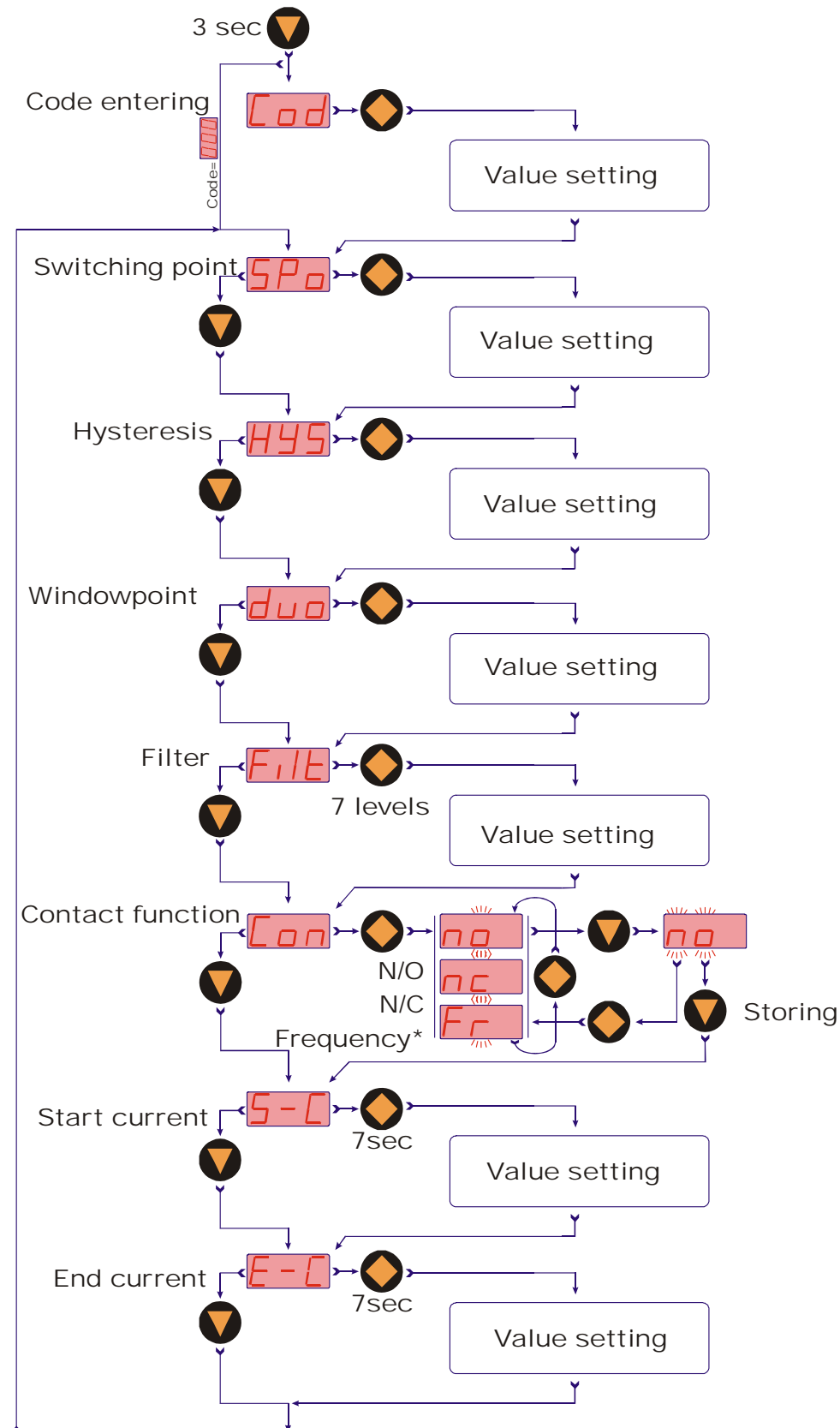

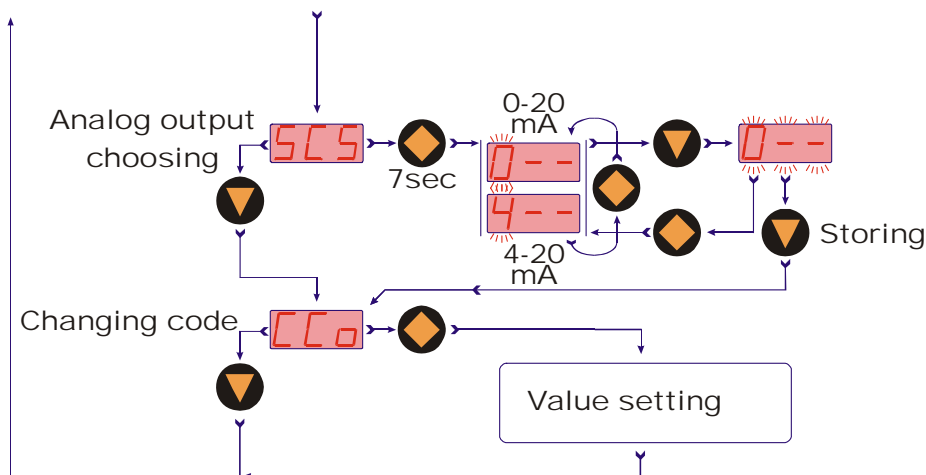

## 8.5 Main menu items

### 8.5.1 Switching point

The switching point is entered in the menu item "**Spo**". A setting value between 000 and 999 can be selected. This value can also include a decimal point. The decimal point can be set at two points (e.g. 10.0 or 1.00). If the measuring value is the set switch point, the electronic is activated and is signalled by a lightning LED.

If the hysteresis is equal to zero and the window point is de-activated, the electronic switches back whenever the indicated value falls below the switching point.

### 8.5.2 Hysteresis

After the setting of switching point, the hysteresis can be entered as a negative value in the "**HYS**" menu. The standard hysteresis value is zero. In operation condition this can lead to ambiguous switching behaviour if the reading fluctuates around the switching point or window point. Aid can be given here by increasing the hysteresis. The hysteresis relates to the switching point and the window point (switching point minus hysteresis; window point plus hysteresis).

**Example:** Switching point 20 L/min; Hysteresis: -2.5 L/min

The electronic switches when 20 L/min is exceeded and switches back when the reading drops below 17.5 L/min.

### 8.5.3 Window point (duo-point)

As well as the switching point, it is also to define a "**duo**" (duo-point), the window point. This must be higher than the switching point. Using the window point and the switching point it is possible to monitor the measurement value in a certain range. The switching point limits the measurement range to smaller values and the window point to larger values.



**If the window point (duo-point) is less than or equal to the switching point, an error report (Er4) will be indicated on the display and its value is deleted and its function is invalid (in the case that the window point and switching point out of adjustment).**

The value is set in the same way as the switching point. The window point is needed for process, monitoring of a certain temperature range.

**Example:** Switching point: 10 L/min; window point: 20 L/min; hysteresis: -1 L/min  
 The electronic switches when 10 L/min is exceeded.  
 If the switching value remains between 9 L/min (10-1) and 21 L/min (20+1), the contact will also remain in active switching condition (LED on). If it exceeds 21 L/min or is below 9 L/min the electronic switches back.

**Switching behaviour**

The following diagram clarifies the switching behaviour of the electronic switch. The contact closes (contact type: no) when it drops below the switching point or the window point. It only opens again if the window point plus hysteresis is exceeded or if it drops below the switching point minus hysteresis. An **LED** indicates the switching condition of the switching point.

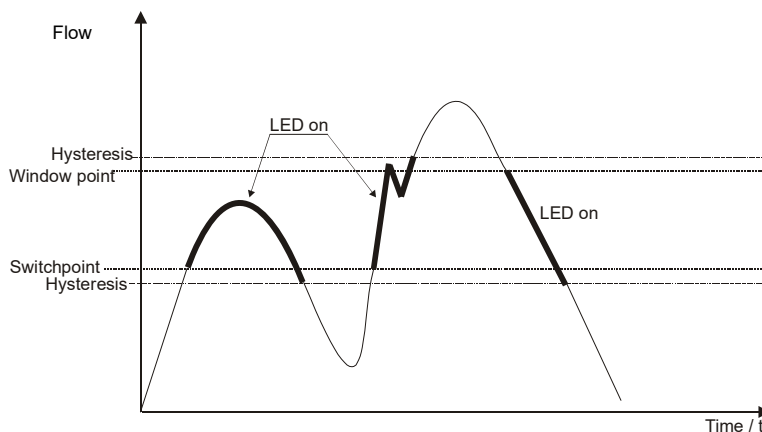
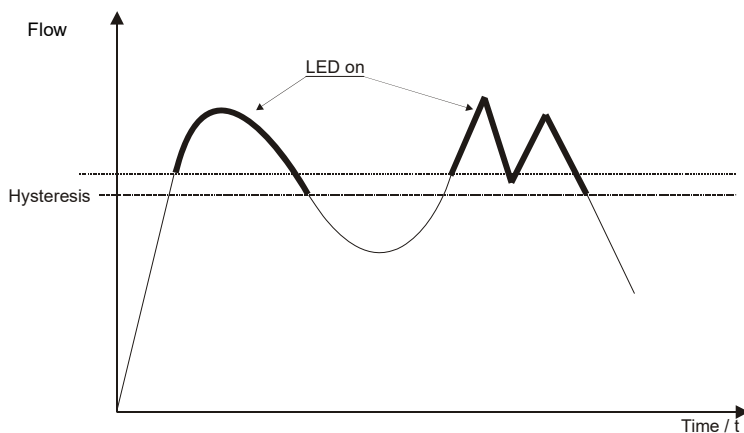

## 8.5.4 Contact type

The function of the transistor switching output is set in menu item "**Con**". The switching function switches from

**no - N/O contact to**

**nc - N/C to**

**Fr – frequency** (Con and Co1 only and for sensors with impulse output)

and back.

N/O contact: contact closes when switching point is exceeded

N/C contact: contact opens when switching point is exceeded

Frequency: frequency output synchronised with the sensor frequency

## 8.5.5 Current output

The current output is selected in menu items

"**S-C**" Start current indicated value < > 0(4) mA

"**E-C**" End current indicated value < > 20 mA

"**SCS**" Start current selection (0-20 mA or 4-20 mA).

The indicated value at which 0(4) mA flow is entered in menu item Start current.

The indicated value at which 20 mA flow is entered in menu item End current.

## 8.5.6 Change Code

The change code option "**CCo**" secures the unit against unauthorised tampering. If the code is different from 000, the user must input the code immediately after entering the adjustment mode.

If you do not remember your code-number, you have to send the unit back to Kobold.

# 9. Maintenance

---

The measurement device requires no maintenance if the measurement medium does not cause deposits or include fiber parts, which wrap around the sensor or the gate. In order to avoid problems, we recommend the installation of a filter, such as the magnetic filter, type MFR.

If it is necessary to clean the sensor, the sensor can be rinsed with a suitable liquid. Fiber parts or large particles can be carefully removed with tweezers, etc.



---

**Ensure that the sensor is not damaged.**

---

Work on the electronics can only be performed by the factory, or the warranty is otherwise voided.

## **10. Technical Information**

---

Operating instructions, data sheet, approvals and further information via the QR code on the device or via [www.kobold.com](http://www.kobold.com)

## **11. Order Codes**

---

Operating instructions, data sheet, approvals and further information via the QR code on the device or via [www.kobold.com](http://www.kobold.com)

## **12. Dimensions**

---

Operating instructions, data sheet, approvals and further information via the QR code on the device or via [www.kobold.com](http://www.kobold.com)

## 13. Disposal

---

### Note!

- Avoid environmental damage caused by media-contaminated parts
- Dispose of the device and packaging in an environmentally friendly manner
- Comply with applicable national and international disposal regulations and environmental regulations.

### Batteries

Batteries containing pollutants are marked with a sign consisting of a crossed-out garbage can and the chemical symbol (Cd, Hg, Li or Pb) of the heavy metal that is decisive for the classification as containing pollutants:

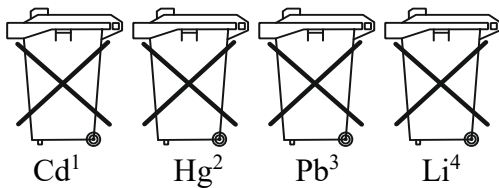

1. „Cd" stands for cadmium
2. „Hg" stands for mercury
3. „Pb" stands for lead
4. „Li" stands for lithium

### Electrical and electronic equipment

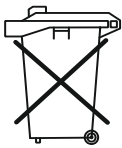



## 14. EU Declaration of Conformance

---

We, KOBOLD Messring GmbH, Nordring 22-24, 65719 Hofheim, Germany, declare under our sole responsibility that the product:

**Compact Vortex Flow meter      Model: DVZ**

to which this declaration relates is in conformity with the following EU directives stated below:

<b>2014/30/EU</b>	<b>EMC Directive</b>
<b>2011/65/EU</b>	<b>RoHS</b>
<b>2015/863/EU</b>	Delegated Directive (RoHS III)

Also, the following standards are fulfilled:

**EN IEC 61326-1:2021**

Electrical equipment for measurement, control and laboratory use. EMC requirements. General requirements, Industrial area (measurement of immunity to RF field up to 1 GHz)

**EN 60529:2014**

Degrees of protection provided by enclosures (IP Code)

**EN IEC 63000:2018** Technical documentation for the assessment of electrical and electronic products with respect to the restriction of hazardous substances

Hofheim, 04 June 2024



H. Volz  
General Manager



J. Burke  
Compliance Manager

## 15. UK Declaration of Conformity

---

We, KOBOLD Messring GmbH, Nordring 22-24, 65719 Hofheim, Germany, declare under our sole responsibility that the product:

**Compact Vortex Flow Meter      Model: DVZ**

to which this declaration relates is in conformity with the following UK directives stated below:

<b>S.I. 2016/1091</b>	Electromagnetic Compatibility Regulations 2016
<b>S.I. 2012/3032</b>	The Restriction of the Use of Certain Hazardous Substances in Electrical and Electronic Equipment Regulations 2012

Also, the following standards are fulfilled:

**BS EN IEC 61326-1:2021**

Electrical equipment for measurement, control and laboratory use. EMC requirements. General requirements, Industrial area (measurement of immunity to RF field up to 1 GHz)

**BS EN 60529:1992+A2:2013**

Degrees of protection provided by enclosures (IP Code)

**BS EN IEC 63000:2018**

Technical documentation for the assessment of electrical and electronic products with respect to the restriction of hazardous substances.

Hofheim, 04 June 2024



H. Volz  
General Manager



J. Burke  
Compliance Manager