



**Operating Instruction
for
Calorimetric flow switch for air**

Model: KAL-L



1. Contents

1. Contents.....	2
2. Note	3
3. Regulated usage	4
4. Operating Principle.....	5
5. Instrument Inspection.....	5
6. Mechanical connection.....	6
7. Electrical connection	7
8. Operation	8
9. Commissioning.....	9
10. Maintenance	10
11. Technical Information.....	10
12. Order Codes	10
13. Dimensions	10
14. Recommended spare parts.....	10
15. Disposal	11
16. EU Declaration of Conformance	12
17. UK Declaration of Conformity.....	13

Sold by:

Kobold Messring GmbH
Nordring 22-24
D-65719 Hofheim
Tel.: +49(0)6192-2990
Fax: +49(0)6192-23398
E-Mail: info.de@kobold.com
Internet: www.kobold.com

2. Note

Please read and take note of these operating instructions before unpacking and setting the unit for operation, and follow the instructions precisely as described herein.

The instruction manuals on our website www.kobold.com are always for currently manufactured version of our products. Due to technical changes, the instruction manuals available online may not always correspond to the product version you have purchased. If you need an instruction manual that corresponds to the purchased product version, you can request it from us free of charge by email (info.de@kobold.com) in PDF format, specifying the relevant invoice number and serial number. If you wish, the operating instructions can also be sent to you by post in paper form against an applicable postage fee.

Operating instructions, data sheet, approvals and further information via the QR code on the device or via www.kobold.com

The devices are only to be used, maintained and serviced by persons familiar with these operating instructions and with the prevailing regulation applying to procedural safety and the prevention of accidents.

When used in machines, the measuring unit should be used only when the machines fulfil the EC-machine guidelines.

3. Regulated usage

The KAL-L is to be installed only in the specified applications. Every usage which exceeds the specifications is considered to be non-specified. Any damages resulting therefrom are not the responsibility of the manufacturer. The user assumes all risk for such usage. The application specifications include the installation, start-up and service requirements specified by the manufacturer.

The devices from the KAL-L model series are used for the monitoring of air flow. The devices can be used from a pipe size of 20 mm upwards.

Flow range: 1 m/s ... 20 m/s (at 20 °C, 1 bar rel)
Please note that the flow range is reduced if any other operating pressure or temperature applies.

Temperature range: -25 °C ... +120 °C

max. pressure: 8 bar

Limiting signal

For monitoring the velocity of air these devices with terminal connection are equipped with a potential free change over contact; devices with plug-connection are with N/O or N/C contact.

Trend indication

A LED bar graph display shows the current flow value and the set switch point via a flashing LED.

Duo-LED

displays the actual status of the relay.

Material

Sensor: Brass nickel plated

Electronic housing: Glass fibre reinforced Polyamid.

The devices of the series KAL-L are used for monitoring air flow only.

4. Operating Principle

The operation of the electronic flow monitor KAL-L... is based on the proven calorimetric principle. A sensor is heated to a few degrees above the temperature of the flow medium. When the medium flows, the heat generated in the sensor is transferred to the medium, i.e., the sensor is cooled. This cooling process is a measure of the flow velocity. A second sensor measures the medium temperature. The electronics compares the resistances of both sensors by means of a Wheatstone bridge circuit, and switches an output relay if the actual value drops below the set switching value.

5. Instrument Inspection

These devices are checked before dispatch and sent away in perfect condition. Should the damage to a device be visible, we recommend a thorough inspection of the delivery packing. In case of damage, please inform your parcel service/ forwarding agent immediately, since they are responsible for damages during transit.

Scope of delivery:

The standard delivery includes:

- Electronic Flow Monitor for Air model: Kal-L

6. Mechanical connection

Before installation

Ensure that the actual system velocity is within the switching range of the device. Ensure that the permitted maximum operating pressure and temperature for the device is not being exceeded. (See section 10. Technical data).

Installation

Mount the sensor by using the compression fitting or the flange into the corresponding pipe and ensure that the sensing elements are in contact with the flowing medium. The tip of the probe has to project into the pipe minimum 10 mm (better > 15 mm) (see sketch below).

Optimally the probe is that far inserted that the sensing elements is located approx. in the centre of the pipe. For pipe sizes larger than 50 mm the sensor shall be mounted as far as possible into the pipe.

Fitting position

The function of the sensor is not dependent on their fitting position. Please note that the marking (1), which is on the hexagon of the sensor, is absolutely parallel to the flow direction. To avoid incorrect function of the sensor the straight pipe upstream should be 10 times ID and downstream 5 times ID.

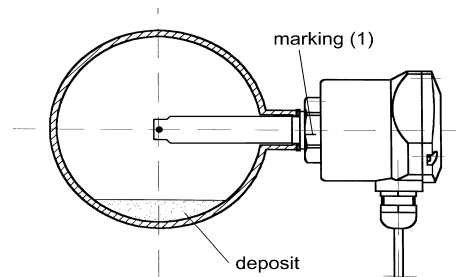

7. Electrical connection

Terminal connection

- Unscrew the cover of the electronics.
- Connect the device according to the information at the terminal ports.
When DC voltage is used no polarity is to be watched.

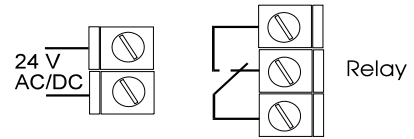

Warning: Ensure that the power is disconnected during the connection of the cable.

- Put supply voltage to the device (24 VAC/DC, -15%, +10%)

Plug connection (Plug M12 x 1)

PIN 1	brown	24 VAC/DC
PIN 2	white	24 VAC/DC
PIN 3	blue	relais N/O or N/C
PIN 4	black	relais N/O or N/C

8. Operation

LED-trend indication

The LED-trend indication (8 LED) is used to display

- the actual flow value (LED-chain starts to light from left end)

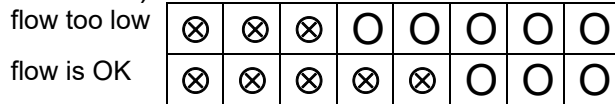

- the set point (third LED from left flashing)

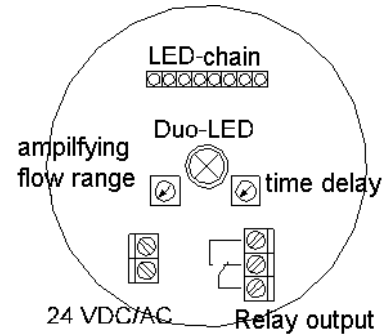

Duo-LED

The Duo-LED is used to display

- the status of the relay
 - red = Alarm (set point not reached; relay is deactivated)
 - green = Flow (set point exceeded; relay is activated)

Terminal ports

The terminal ports are used to connect the power supply and the relay output. The device needs 24 VDC/VAC. No polarity is to be watched.

Potentiometer (range amplification)

The switch point is always set on the third LED from left. With the left potentiometer, the amplification of the range and the maximum position of flow value are set on the LED bar display. Depending on the distance of maximum value LED from switch point LED, small or large flow variations are permitted.

Potentiometer for time delay after start up

With the right potentiometer the time delay (1 to 60 seconds) can be adjusted. If the power supply is switched on the relay is activated until the delay time is passed. The flow switch indicates "FLOW". After the time delay passed the device switches into measuring mode.

9. Commissioning

The use of this switch in machines acc. to directive 2006/42/EC is prohibited until the complete machine complies with this directive.

After mechanical and electrical installation of the sensor the device has to be put into operation as described in this section.

Switch on the supply voltage to the device.

Adjustment of the time delay after start up

If the power supply is switched on the relay is activated until the delay time is passed. The flow switch indicates "FLOW" even if the flow rate is lower.

The time delay can be adjusted in a range of 1 to 60 seconds. After the time delay passed the device switches into measuring mode.

- Turning the potentiometer clockwise increases the time delay.

Set point adjustment

The set point is factory preset. It is indicated by the third LED from left hand side flashing. The adjustment of the set point is done by an adjustment of the amplification of the range.

Regulate the flow to the required flow rate.

- **Max. monitoring:** Adjust the amplification with the left potentiometer until one or two LEDs left from the set point (third LED) are lit.

1 LED left of set point LED

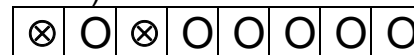

--> setpoint close above actual flow rate, relay deactivated

- **Min. monitoring:** Adjust the amplification with the left potentiometer until some LEDs right from the set point (third LED) are lit.

1 LED right of set point LED

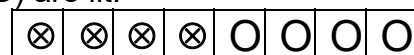

--> setpoint close below actual flow rate, relay activated

5 LED`s right of set point LED

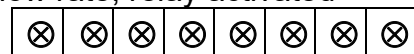

--> set point far below actual flow rate, relay activated

After mounting of the cover the flow switch is ready for use.

10. Maintenance

The device is maintenance free. The sensor shall be visually checked and possibly cleaned with air.

11. Technical Information

Operating instructions, data sheet, approvals and further information via the QR code on the device or via www.kobold.com

12. Order Codes

Operating instructions, data sheet, approvals and further information via the QR code on the device or via www.kobold.com

13. Dimensions

Operating instructions, data sheet, approvals and further information via the QR code on the device or via www.kobold.com

14. Recommended spare parts

We do not recommend any spare parts. In case of defect the device has to be returned to the supplier.

15. Disposal

Note!

- Avoid environmental damage caused by media-contaminated parts
- Dispose of the device and packaging in an environmentally friendly manner
- Comply with applicable national and international disposal regulations and environmental regulations.

Batteries

Batteries containing pollutants are marked with a sign consisting of a crossed-out garbage can and the chemical symbol (Cd, Hg, Li or Pb) of the heavy metal that is decisive for the classification as containing pollutants:

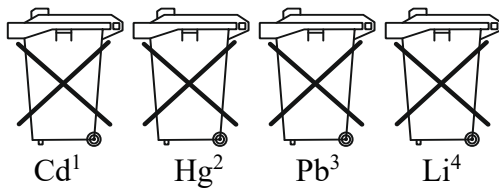

1. „Cd" stands for cadmium
2. „Hg" stands for mercury
3. „Pb" stands for lead
4. „Li" stands for lithium

Electrical and electronic equipment

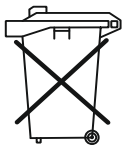

16. EU Declaration of Conformance

We, KOBOLD Messring GmbH, Nordring 22-24, 65719 Hofheim, Germany, declare under our sole responsibility that the product:

Electronic Flow Monitor Model: KAL-L

to which this declaration relates is in conformity with the following EU directives stated below:

2014/35/EU	Low Voltage Directive
2014/30/EU	EMC Directive
2011/65/EU	RoHS (category 9)

Also, the following standards are fulfilled:

EN 61000-6-2:2011

Electromagnetic compatibility (EMC) - Part 6-2: Generic standards - Immunity for industrial environments

EN 61000-6-3:2011

Electromagnetic compatibility (EMC) - Part 6-3: Generic standards - Emission standard for residential, commercial and light-industrial environments

EN 55011:2011

Industrial, scientific and medical equipment - Radio-frequency disturbance characteristics - Limits and methods of measurement

EN 61010-1:2010

Safety requirements for electrical equipment for measurement, control and laboratory use - Part 1: General requirements

EN 50581:2012

Technical documentation for the assessment of electrical and electronic products with respect to the restriction of hazardous substances

Hofheim, 25 Sept 2023



H. Volz
General Manager

J. Burke
Compliance Manager

17. UK Declaration of Conformity

We, KOBOLD Messring GmbH, Nordring 22-24, 65719 Hofheim, Germany, declare under our sole responsibility that the product:

Electronic Flow Monitor Model: KAL-L

to which this declaration relates is in conformity with the following UK directives stated below:

S.I. 2016/1091	Electromagnetic Compatibility Regulations 2016
S.I. 2012/3032	The Restriction of the Use of Certain Hazardous Substances in Electrical and Electronic Equipment Regulations 2012

Also, the following standards are fulfilled:

BS EN 60947-5-9:2007

Low-voltage switchgear and controlgear Control circuit devices and switching elements. Flow rate switches

BS EN IEC 63000:2018

Technical documentation for the assessment of electrical and electronic products with respect to the restriction of hazardous substances.

Hofheim, 25 Sept 2023



H. Volz
General Manager



J. Burke
Compliance Manager