



**Operating Instructions
for
Electronic Temperature Sensor**

Model: TDA



1. Contents

1. Contents.....	2
2. Note	3
3. Instrument Inspection.....	3
4. Regulated Use	3
5. Operating Principle.....	4
6. Mechanical Connection.....	4
7. Electrical Connection	5
7.1. Connector pin assignment TDA-...L3M	5
7.2. Connector pin assignment TDA-...P3M, TDA-...N3M.....	6
8. Operation	7
8.1. Button function.....	7
9. Settings.....	8
9.1. Value setting	8
10. Set-up Mode	9
10.1. TDA-...L3M, TDA-...L3P, TDA-...L3S	9
10.2. TDA-...P3M, TDA-...N3M	10
11. Main Menu Items.....	12
11.1. Current output.....	12
11.2. Switching point.....	12
11.3. Hysteresis	12
11.4. Window point (duo-point).....	12
11.5. Switching behaviour.....	13
11.6. Transient response	14
11.7. Contact type.....	14
11.8. Change code	14
12. Maintenance	14
13. Technical Information.....	15
14. Order Codes	15
15. Dimensions	15
16. Disposal	16
17. EU Declaration of Conformance	17
18. UK Declaration of Conformity.....	18

Manufactured and sold by:

Kobold Messring GmbH
Nordring 22-24
D-65719 Hofheim
Tel.: +49(0)6192-2990
Fax: +49(0)6192-23398
E-Mail: info.de@kobold.com
Internet: www.kobold.com

2. Note

Please read these operating instructions before unpacking and putting the unit into operation. Follow the instructions precisely as described herein.

The instruction manuals on our website www.kobold.com are always for currently manufactured version of our products. Due to technical changes, the instruction manuals available online may not always correspond to the product version you have purchased. If you need an instruction manual that corresponds to the purchased product version, you can request it from us free of charge by email (info.de@kobold.com) in PDF format, specifying the relevant invoice number and serial number. If you wish, the operating instructions can also be sent to you by post in paper form against an applicable postage fee.

Operating instructions, data sheet, approvals and further information via the QR code on the device or via www.kobold.com

The devices are only to be used, maintained and serviced by persons familiar with these operating instructions and in accordance with local regulations applying to Health & Safety and prevention of accidents.

When used in machines, the measuring unit should be used only when the machines fulfil the EC-machine guidelines.

3. Instrument Inspection

Instruments are inspected before shipping and sent out in perfect condition.

Should damage to a device be visible, we recommend a thorough inspection of the delivery packaging. In case of damage, please inform your parcel service / forwarding agent immediately, since they are responsible for damages during transit.

Scope of delivery:

The standard delivery includes:

- Electronic Temperature Sensor, model: TDA

4. Regulated Use

Any use of the Electronic Temperature Sensor, model: TDA which exceeds the manufacturer's specifications may invalidate its warranty. Therefore, any resulting damage is not the responsibility of the manufacturer. The user assumes all risk for such usage. The application specifications include the installation, start-up and service requirements specified by the manufacturer.

5. Operating Principle

The KOBOLD Model TDA temperature sensor is used for economical measuring and monitoring of temperature. It can be used for any application in which temperatures must be monitored with great accuracy.

The sensor element is a semiconductor that outputs a digital signal to the electronic analyser in 0,5°C steps. The measured values are shown on a 3-place LED display. The analogue output can be adjusted as required with the measuring range.

6. Mechanical Connection

Before installation:

- Make sure the maximum operating pressure and maximum service temperature for this instrument are not exceeded.

Installation:

- This device is installed in a matching sleeve. Use sealing tape (i.e. Teflon tape) or a flat gasket to seal the threaded connections.
- The mounting position should be selected so that the sensor tip is always immersed in the liquid being monitored, thus ensuring optimal heat exchange between the liquid and the temperature sensor.
- Note that deposits that build up on the sensor tip or dirty liquids can have an insulating effect and cause invalid measurements.
- Whenever possible, after the mechanical installation is complete, the joint at the threaded connector and the supply piping should be checked to ensure that it is tight and does not leak.

7. Electrical Connection



Caution! Be sure that the supply voltage of your system is the same as that specified on the device nameplate.

- Make sure that the electrical supply lines are de-energized.
- Make the connection using a PVC cable or the M 12x1 connector socket, as shown in the accompanying diagram.
- Appropriate connectors with different cable lengths are optionally available.



Important! The instrument electronics may be damaged if the connectors are assigned incorrectly.

7.1. Connector pin assignment TDA-...L3M

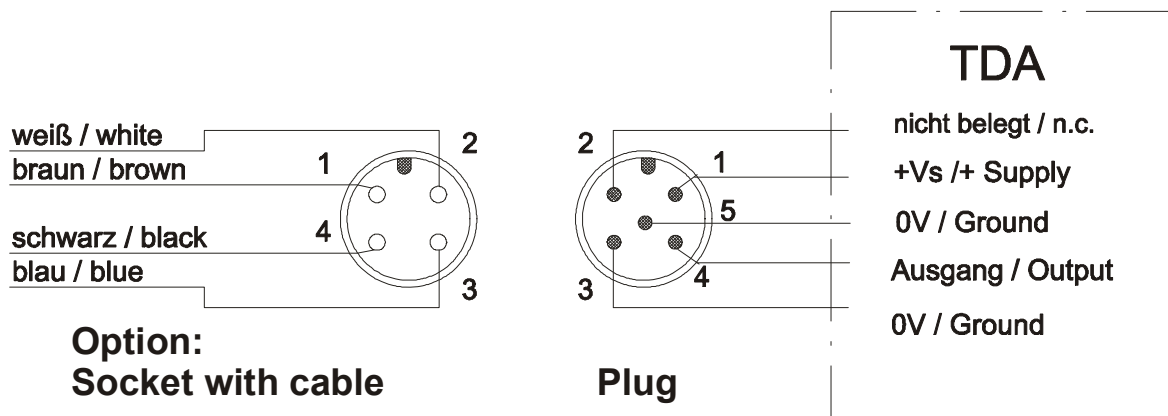

Connection example

TDA-...L3M/Plug M12

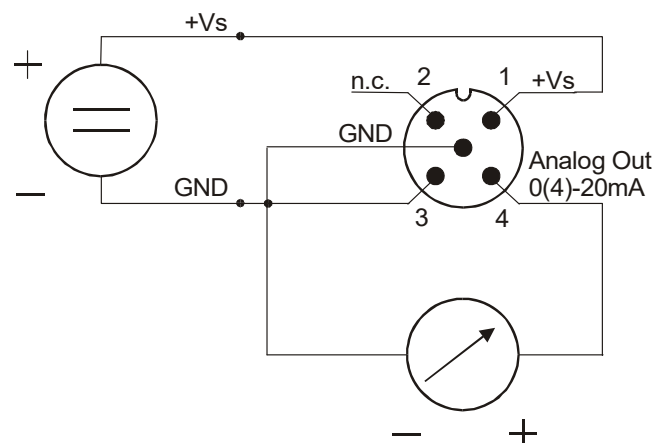

7.2. Connector pin assignment TDA-...P3M, TDA-...N3M

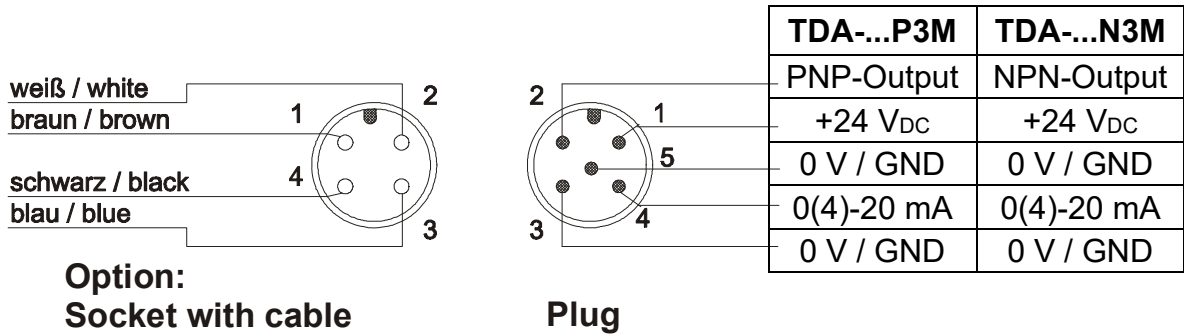

Cable connector assignment

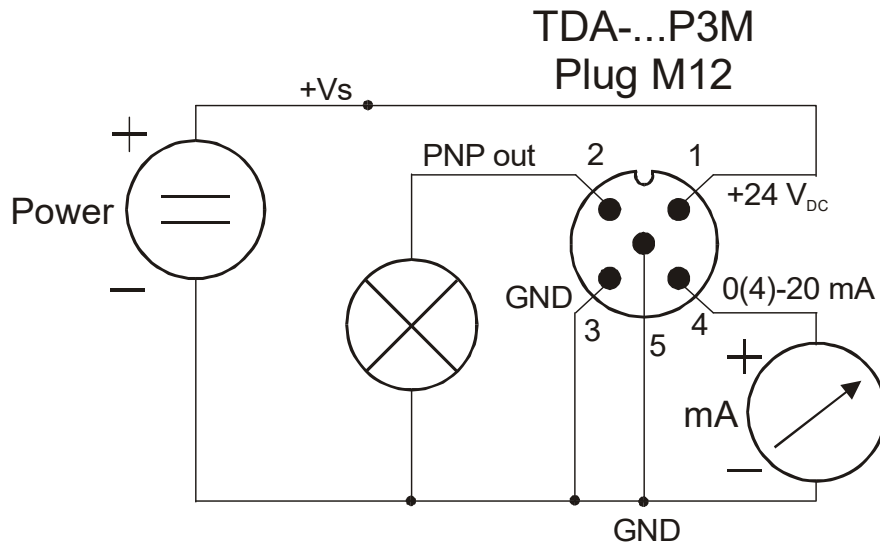

8. Operation



Caution! Please note that when used in high temperature applications, the device housing and the operating controls can become very hot.

Connect the temperature sensor as shown in the previous wiring diagram and then connect it to a power source of the specified voltage.

8.1. Button function

In the normal mode (measuring mode)

 : Press 3 secs → Set-up mode

In the set-up mode

 : Next Step

 : Change Value

Any time

3 sec 

or do not press
a button for 20 sec



Standard mode

9. Settings

The following values can be changed at the temperature transmitter:

	Scale Range	Factory Setting
Start current (S-C)	0...FS	0
End current (E-C)	0...FS	FS
Start current selection (SCS)	0 / 4	4
Change code (CCo,)	000...999	000

9.1. Value setting

From the main menu item (for example: start current, "**S-C**"), press the "◆" button to set the value. The flow chart below illustrates the universal routine for changing individual parameters.

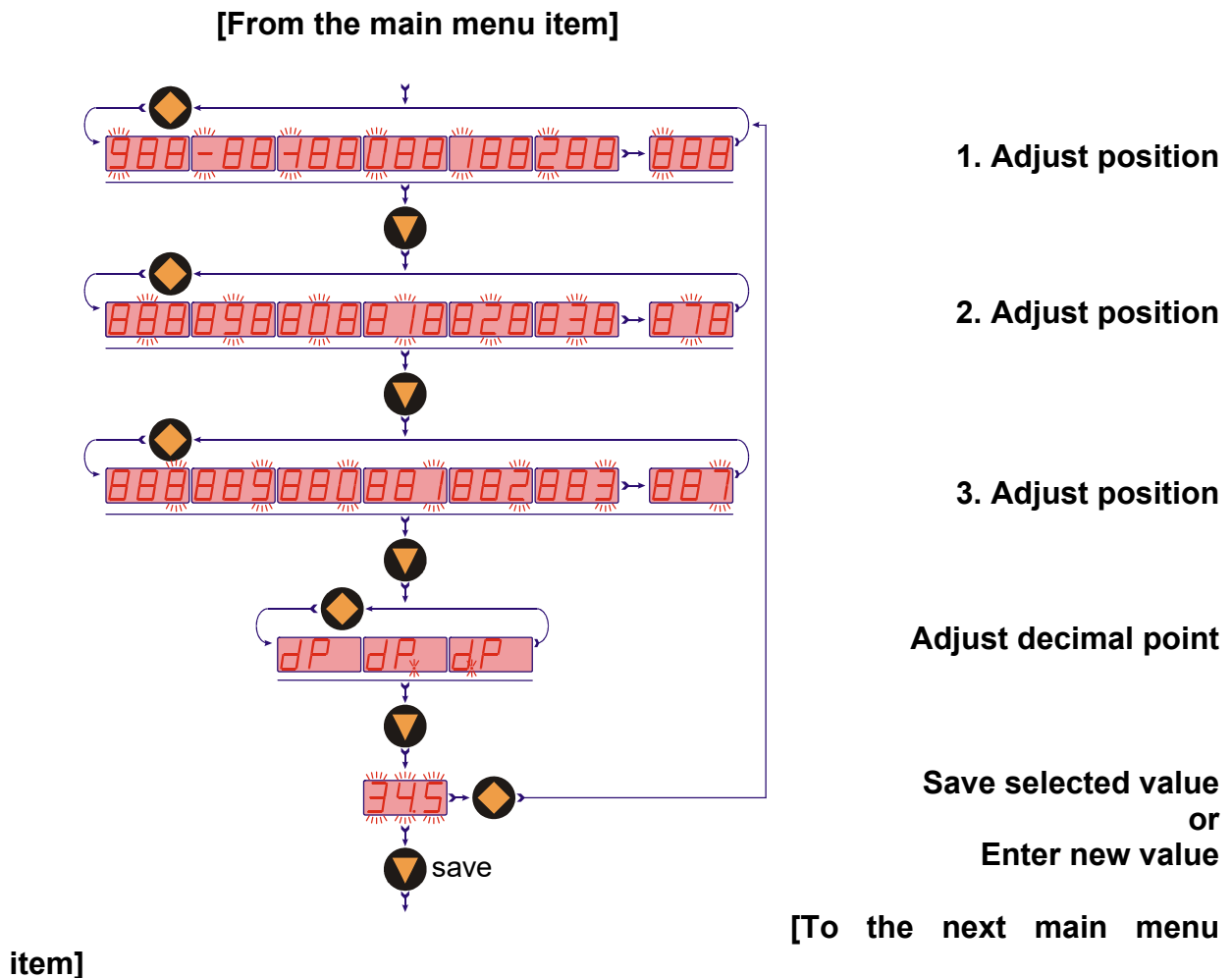

10. Set-up Mode

10.1. TDA-...L3M, TDA-...L3P, TDA-...L3S

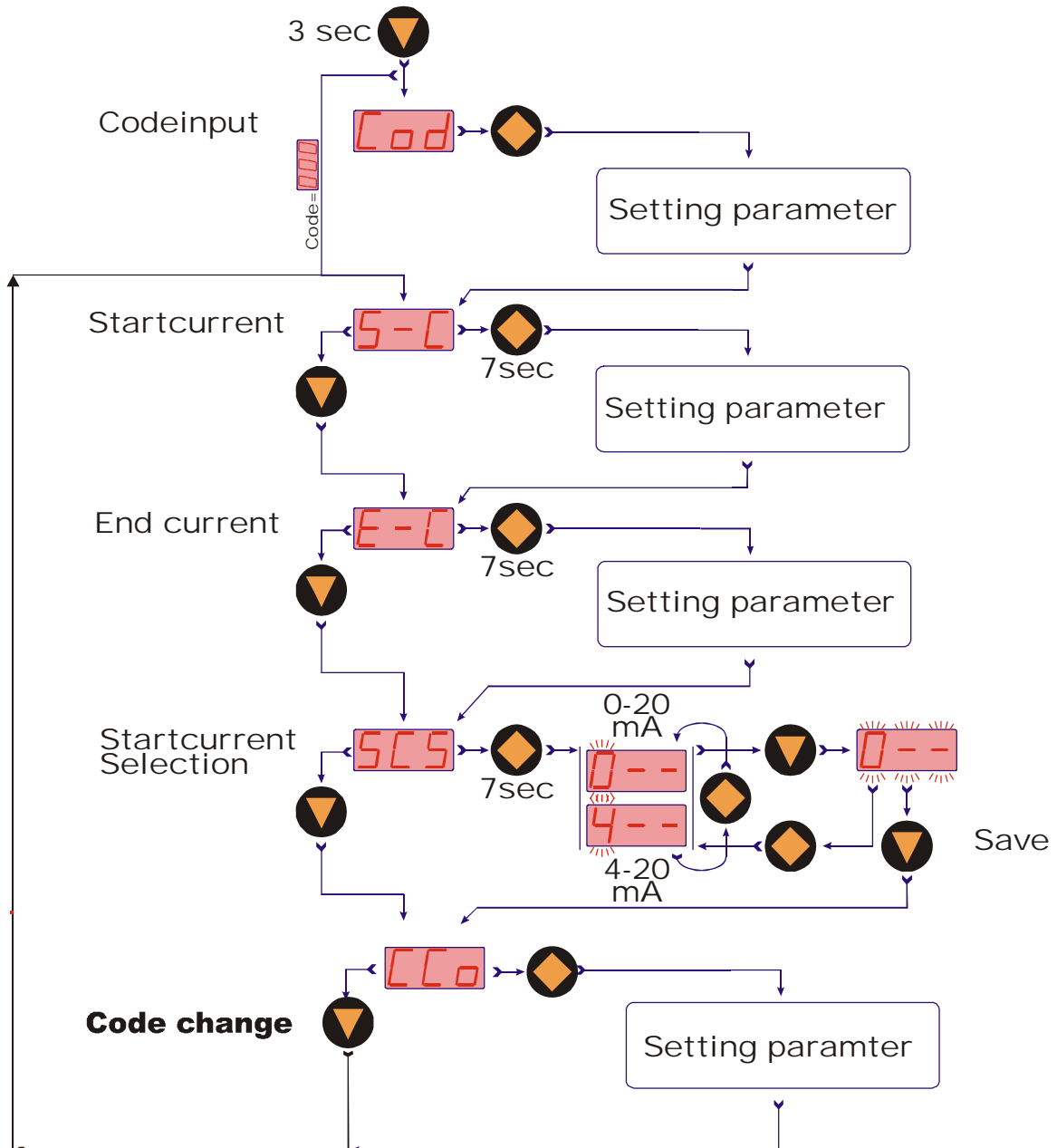

10.2. TDA-...P3M, TDA-...N3M

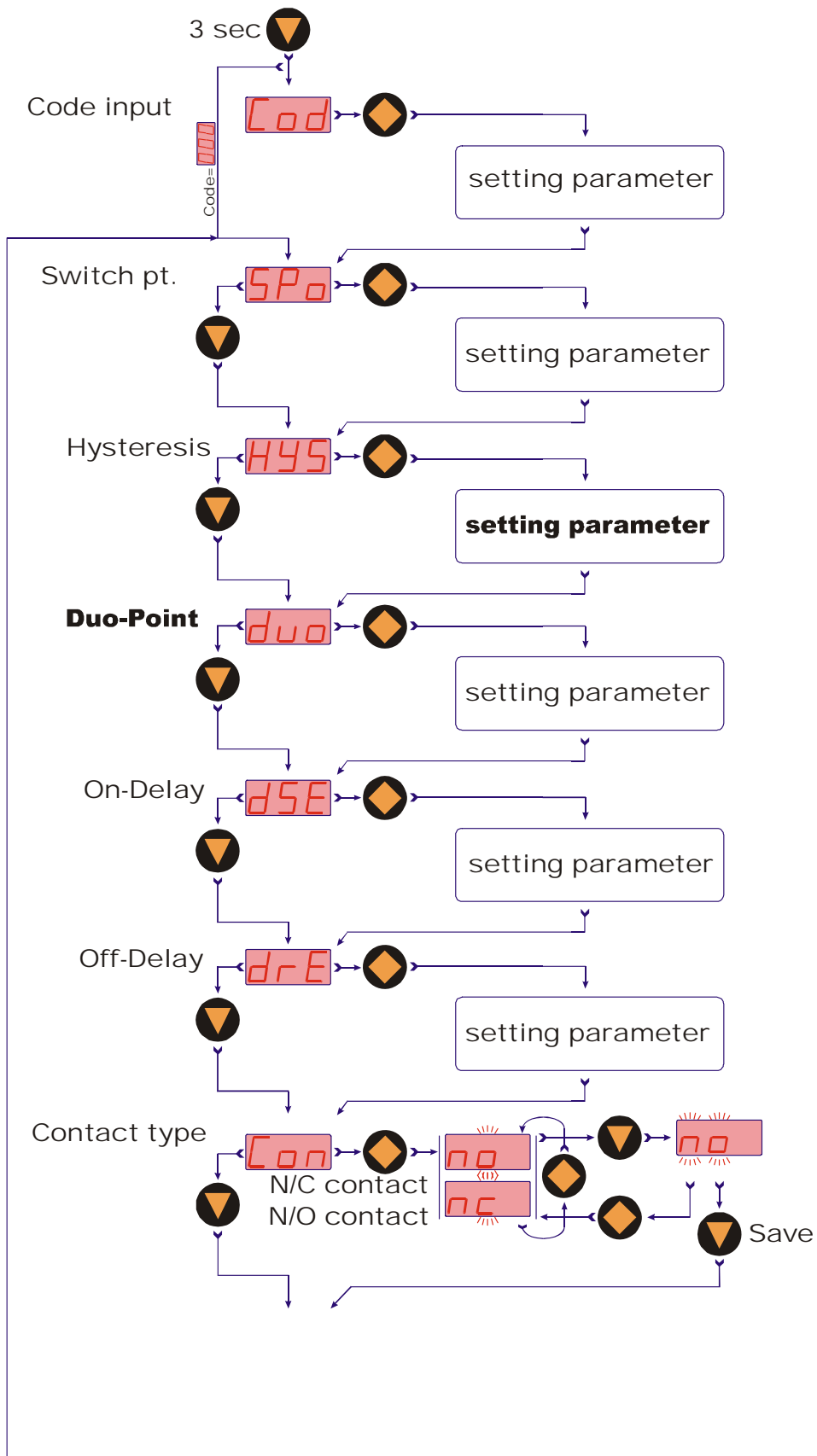

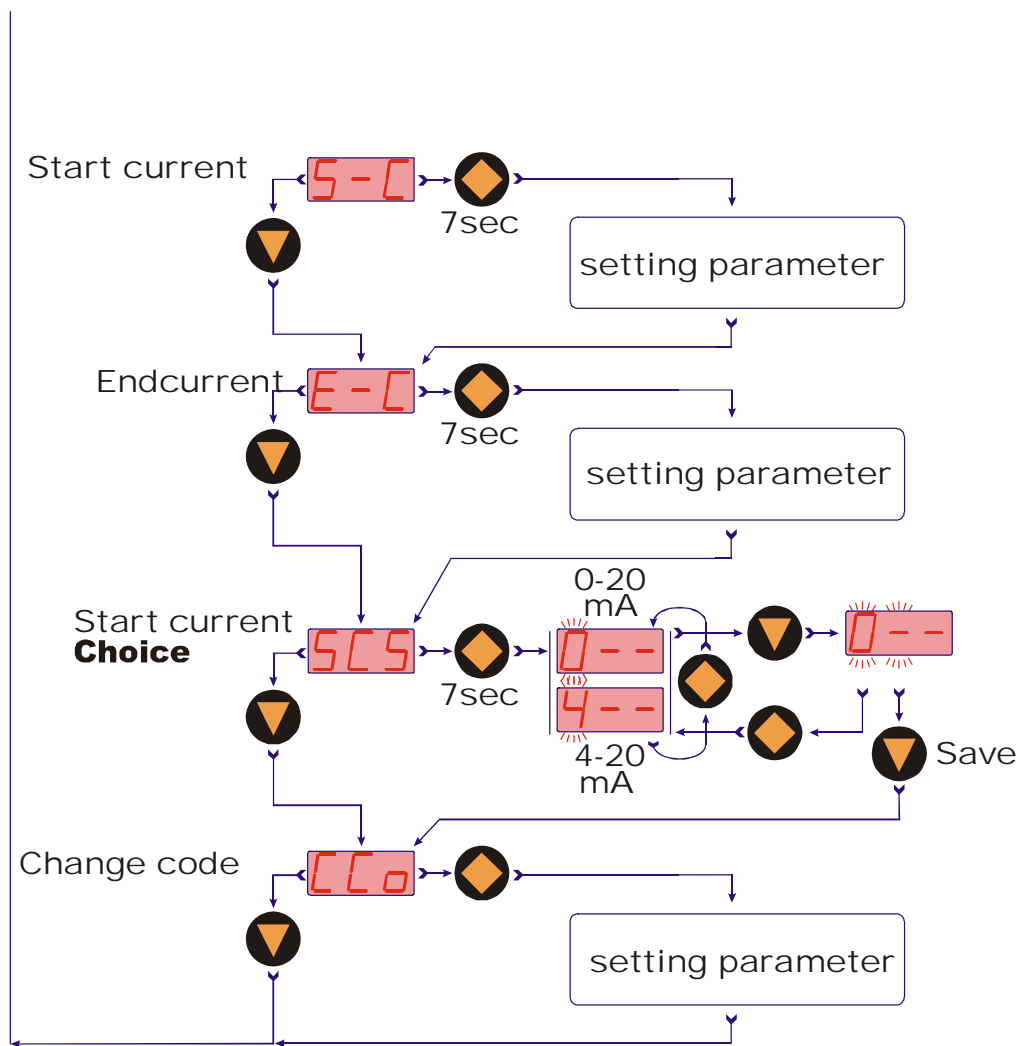

11. Main Menu Items

11.1. Current output

The current output is selected as follows:

"S-C" Start current indicated value $< > 0(4)$ mA

"E-C" End current indicated value $< > 20$ mA

"SCS" Start current selection (0-20 mA or 4-20 mA).

The indicated value at which 0(4) mA flows is entered in menu item "S-C". The indicated value at which 20 mA flows is entered in menu item "E-C".

11.2. Switching point

The switching point is entered in the menu item "SPo". A setting value between -199 and 999 can be selected. This value can also include a decimal point. The decimal point can be set at two points (e.g. 10.0 or 1.00). If the measuring value is the set switch point, the temperature switch is activated and is signalled by a lighted LED.

If the hysteresis is zero and the window point is inactive, the temperature switch will be reacted if the temperature is below the switch point.

11.3. Hysteresis

After setting the switching point, the hysteresis can be entered as a negative value in the "HYS" menu. The standard hysteresis value is zero. In operation condition this can lead to ambiguous switching behaviour if the reading fluctuates around the switching point or window point. This can be prevented by increasing the hysteresis. The hysteresis relates to the switching point and the window point (switching point minus hysteresis; window point plus hysteresis).

Example: Switching point 100 °C; Hysteresis: -2.5 °C

The temperature switch switches when 100 °C is exceeded and switches back when the reading drops below 97.5 °C.

11.4. Window point (duo-point)

Along with the switching point, the "duo" (duo-point) has to be defined, known as the window point. This must be higher than the switching point. By using the window point and the switching point it is possible to monitor the measurement value in a certain range. The switching point limits the measurement range to smaller values and the window point to larger values.



If the window point (duo-point) is less than or equal to the switching point, an error report (Er4) will be indicated on the display. The value is deleted and its function is invalid (in the case that the window point and switching point out of adjustment).

The value is set in the same way as the switching point.
 The window point is needed for process, monitoring of a certain temperature range.

Example: Switching point: 50 °C; window point: 70 °C; hysteresis: -2 °C

The temperature contact switches when 50 °C is exceeded.

If the temperature remains between 48 °C (50-2) and 72 °C (70+2), the contact will remain in active switching condition (LED on). If it exceeds 72 °C or drops below 48 °C , the contact will de-energise.

11.5. Switching behaviour

The following diagram clarifies the switching behaviour of the temperature switch. The contact closes (contact type: no) when it drops below the switching point or the window point. It only opens again if the window point plus hysteresis is exceeded or if it drops below the switching point minus hysteresis. An **LED** indicates the switching condition of the switching point.

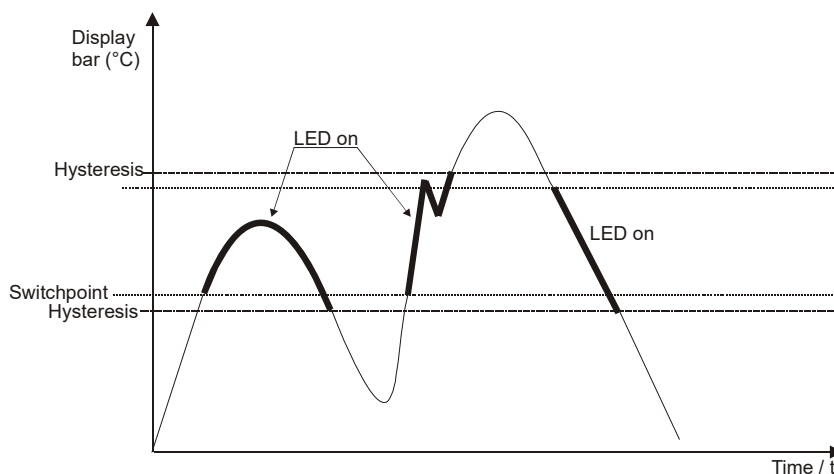
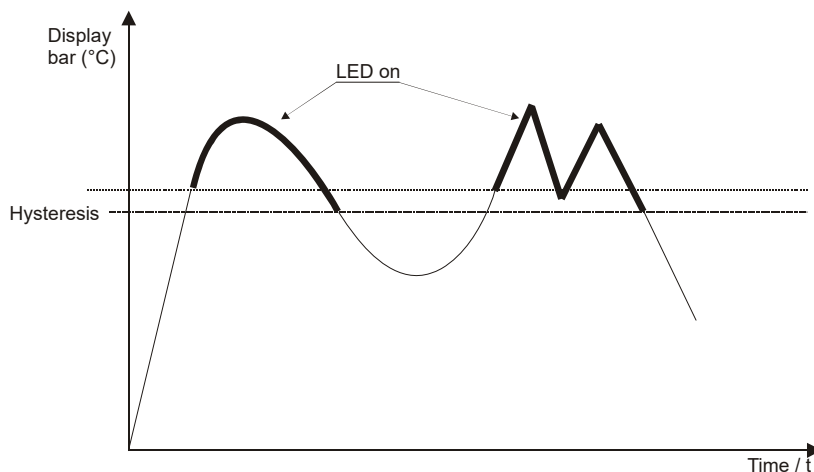

11.6. Transient response

Using the menu items “**dSE**” and “**drE**” it is possible to set the delay set and the delay reset.

The delay set causes delayed switching of the output if the switching threshold is exceeded.

The delay reset causes a delayed resetting of the output if it drops below the switching threshold – hysteresis.

The setting range for both parameters is 0.0 ... 99.5 seconds. The step rate is 0.5 seconds.

With these two functions it is also possible to suppress temporary disturbances.

11.7. Contact type

The transistor switching output can be set in the "**Con**" menu. The switching function changes from

no - **NO**
to
nc - **N/C** and back.

NO switch means: the transistor is switched through if the switching point is exceeded.

N/C contact means: The output transistor is cut off when the switching point is exceeded.

11.8. Change code

Change code "**CCo**" protects the device against unauthorised changing of the set parameters. If the code set is different from 000, then the operator must enter the set code before selecting the set-up mode.

12. Maintenance

This device is maintenance-free when properly installed. However, deposits from dirty liquids can lead to invalid measured values.

13. Technical Information

Operating instructions, data sheet, approvals and further information via the QR code on the device or via www.kobold.com

14. Order Codes

Operating instructions, data sheet, approvals and further information via the QR code on the device or via www.kobold.com

15. Dimensions

Operating instructions, data sheet, approvals and further information via the QR code on the device or via www.kobold.com

16. Disposal

Note!

- Avoid environmental damage caused by media-contaminated parts
- Dispose of the device and packaging in an environmentally friendly manner
- Comply with applicable national and international disposal regulations and environmental regulations.

Batteries

Batteries containing pollutants are marked with a sign consisting of a crossed-out garbage can and the chemical symbol (Cd, Hg, Li or Pb) of the heavy metal that is decisive for the classification as containing pollutants:

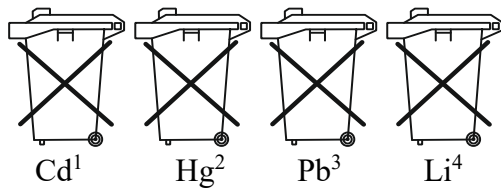

1. „Cd" stands for cadmium
2. „Hg" stands for mercury
3. „Pb" stands for lead
4. „Li" stands for lithium

Electrical and electronic equipment

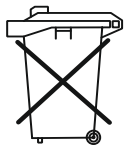

17. EU Declaration of Conformance

We, KOBOLD-Messring GmbH, Hofheim-Ts, Germany, declare under our sole responsibility that the product:

Electronic temperature sensor, model TDA

to which this declaration relates is in conformity with the standards noted below:

EN IEC 61326-1:2021

Electrical equipment for control and instrumentation technology and laboratory use – EMC-requirements, industrial area (measurement of interference immunity to HF fields up to 1 GHz)

EN 61010-1:2010 + A1:2019 + A1:2019/AC:2019

Safety requirements for electrical measuring-, control- and laboratory instruments.

EN IEC 63000:2018 Technical documentation for the assessment of electrical and electronic products with respect to the restriction of hazardous substances

Also, the following EC guidelines are fulfilled:

2014/30/EU
2011/65/EU
2015/863/EU

EMC Directive
RoHS (category 9)
Delegated Directive (RoHS III)

Hofheim, 08 May 2023

H. Volz
General Manager

M. Wenzel
Proxy Holder

18. UK Declaration of Conformity

We, KOBOLD Messring GmbH, Hofheim-Ts, Germany, declare under our sole responsibility that the product:

Electronic temperature sensor, model TDA

to which this declaration relates is in conformity with the standards noted below:

BS EN IEC 61326-1:2021

Electrical equipment for measurement, control and laboratory use. EMC requirements. General requirements, industrial area (measurement of interference immunity to HF fields up to 1 GHz)

BS EN 61010-1:2010+A1:2019

Safety requirements for electrical equipment for measurement, control, and laboratory use. General requirements

BS EN IEC 63000:2018

Technical documentation for the assessment of electrical and electronic products with respect to the restriction of hazardous substances.

Also, the following UK guidelines are fulfilled:

S.I. 2016/1091

S.I. 2012/3032

Electromagnetic Compatibility Regulations 2016

The Restriction of the Use of Certain Hazardous Substances in Electrical and Electronic Equipment Regulations 2012

Hofheim, 08 May 2023



H. Volz
General Manager

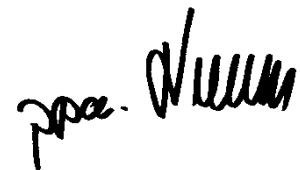

M. Wenzel
Proxy Holder